

# Тумба Varna

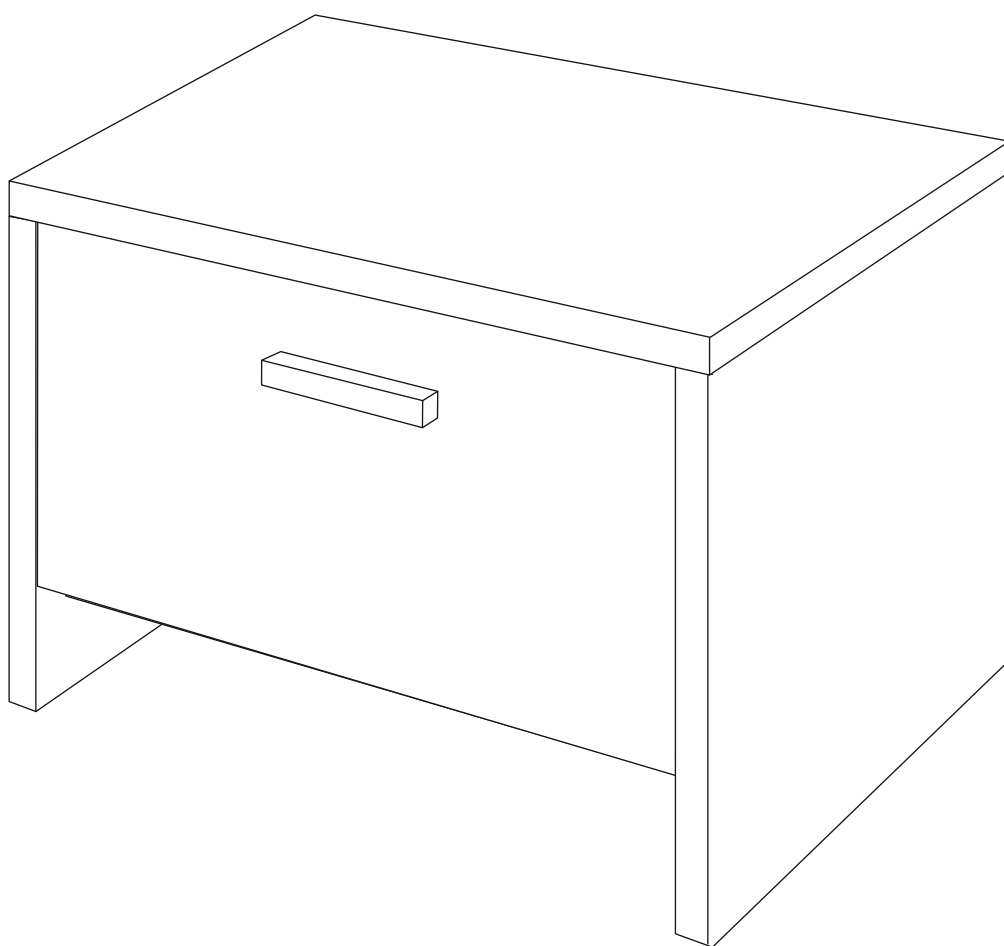

**PROXSON**

правила хорошего сна

**Φ1**

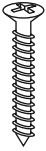

14x

**Φ2**

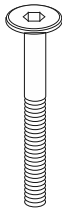

8x

**Φ3**



12x

**Φ4**



12x

**Φ5**



8x

**Φ6**



12x

**Φ7**



4x

**Φ8**

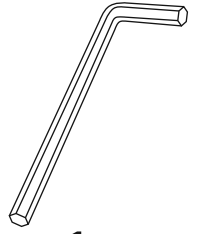

1x

**Φ9**



25x

**Φ10**

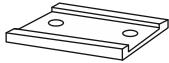

4x

**Φ11**

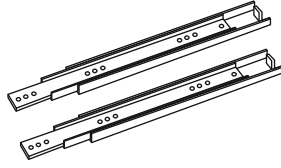

1x

**Φ12**



2x

**Φ13**

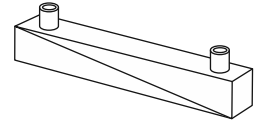

1x

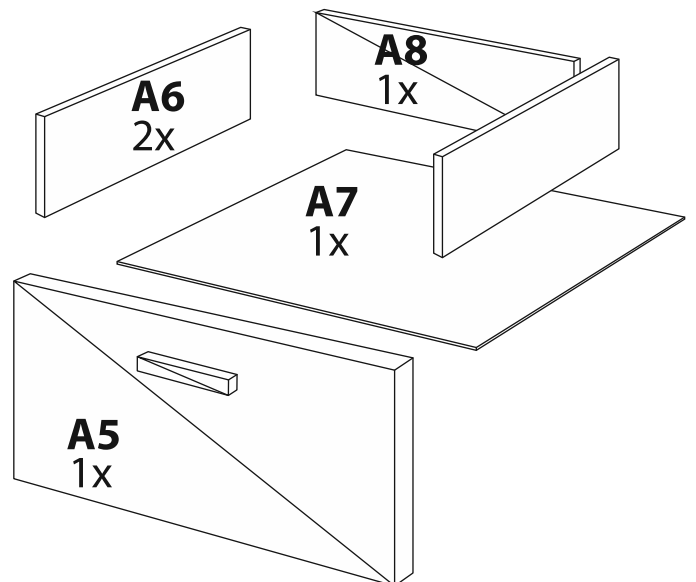
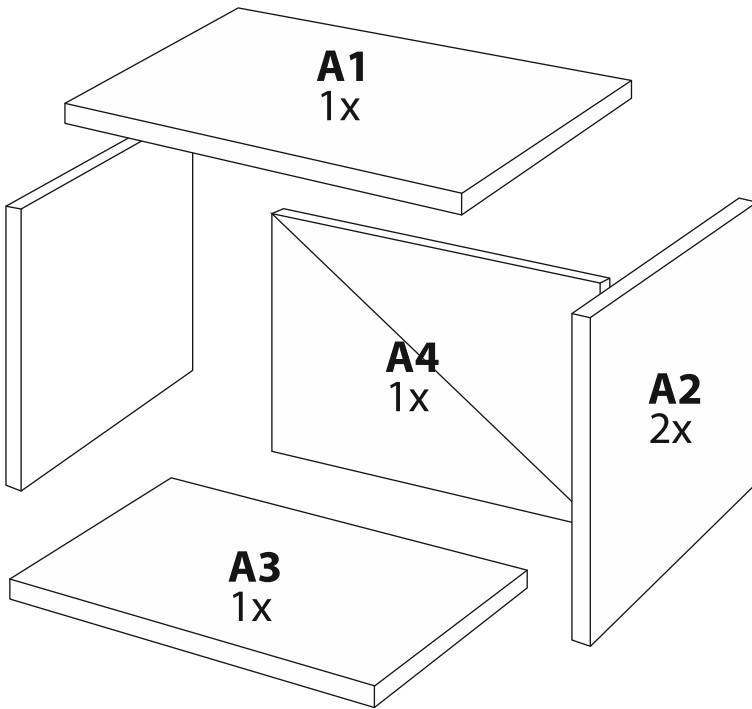

**1**

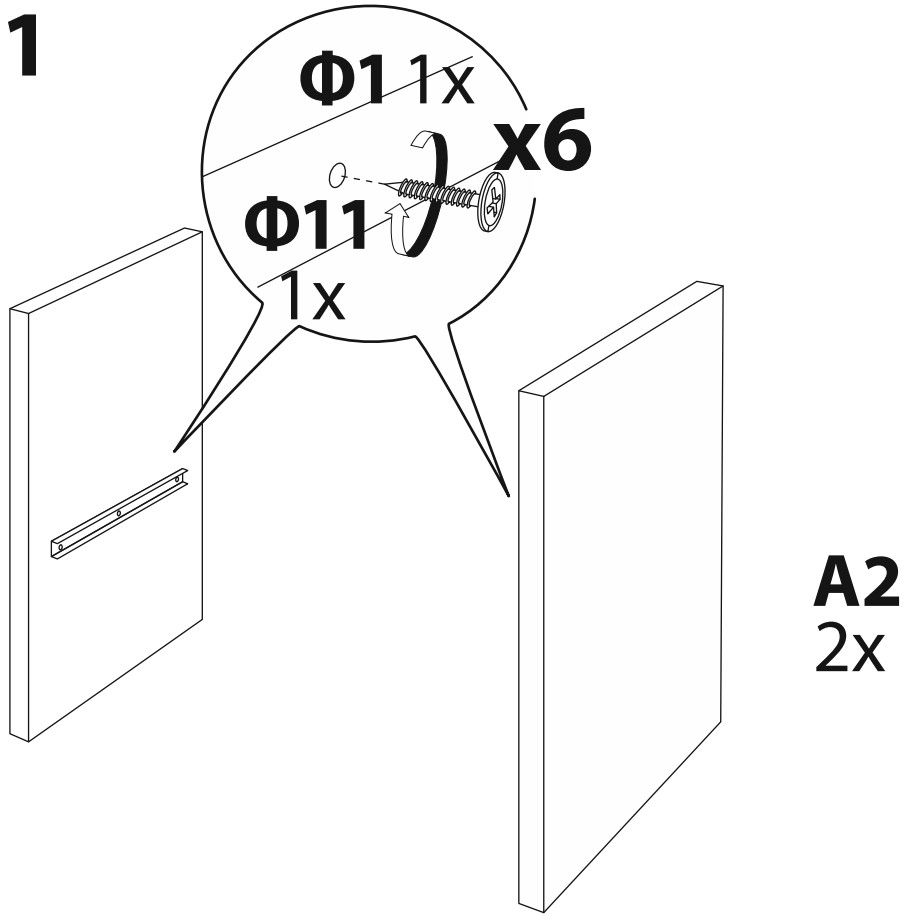

**2**

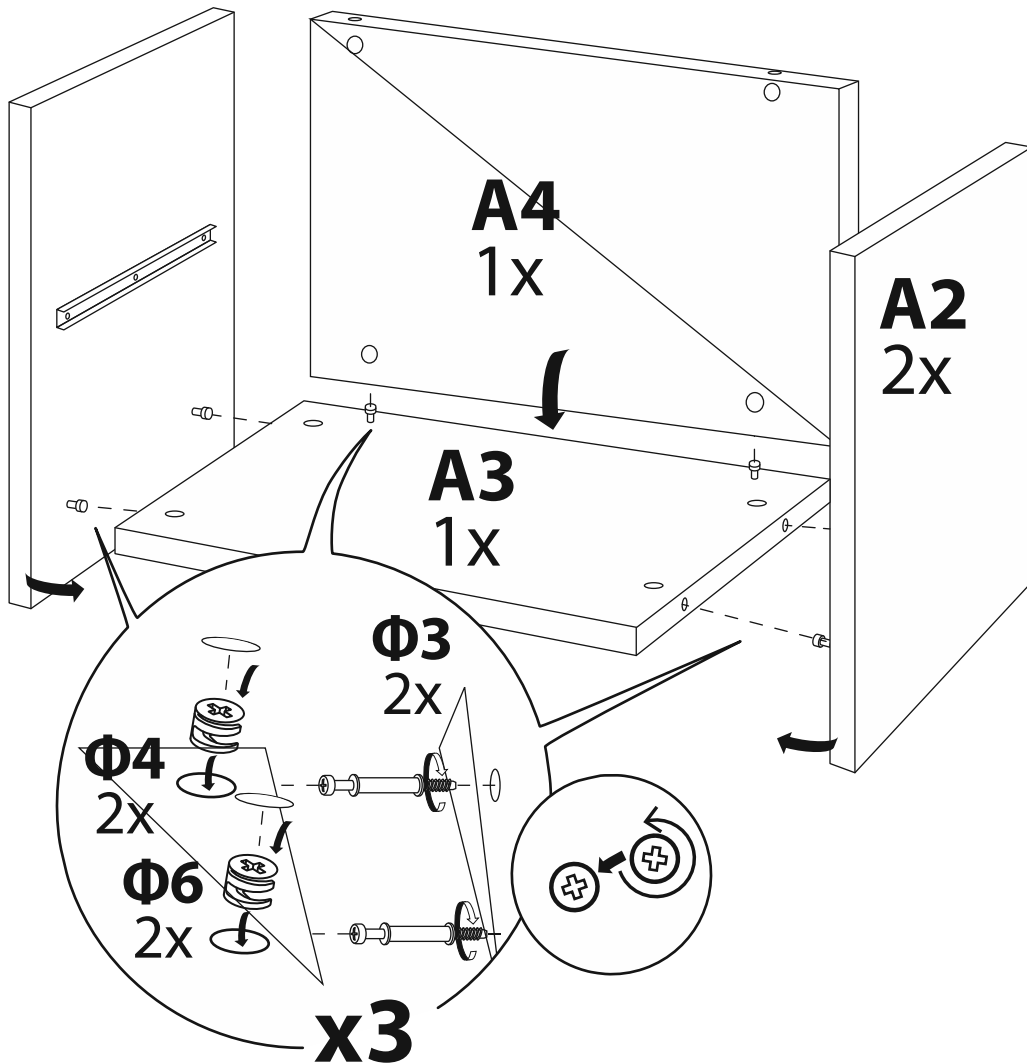

# 3

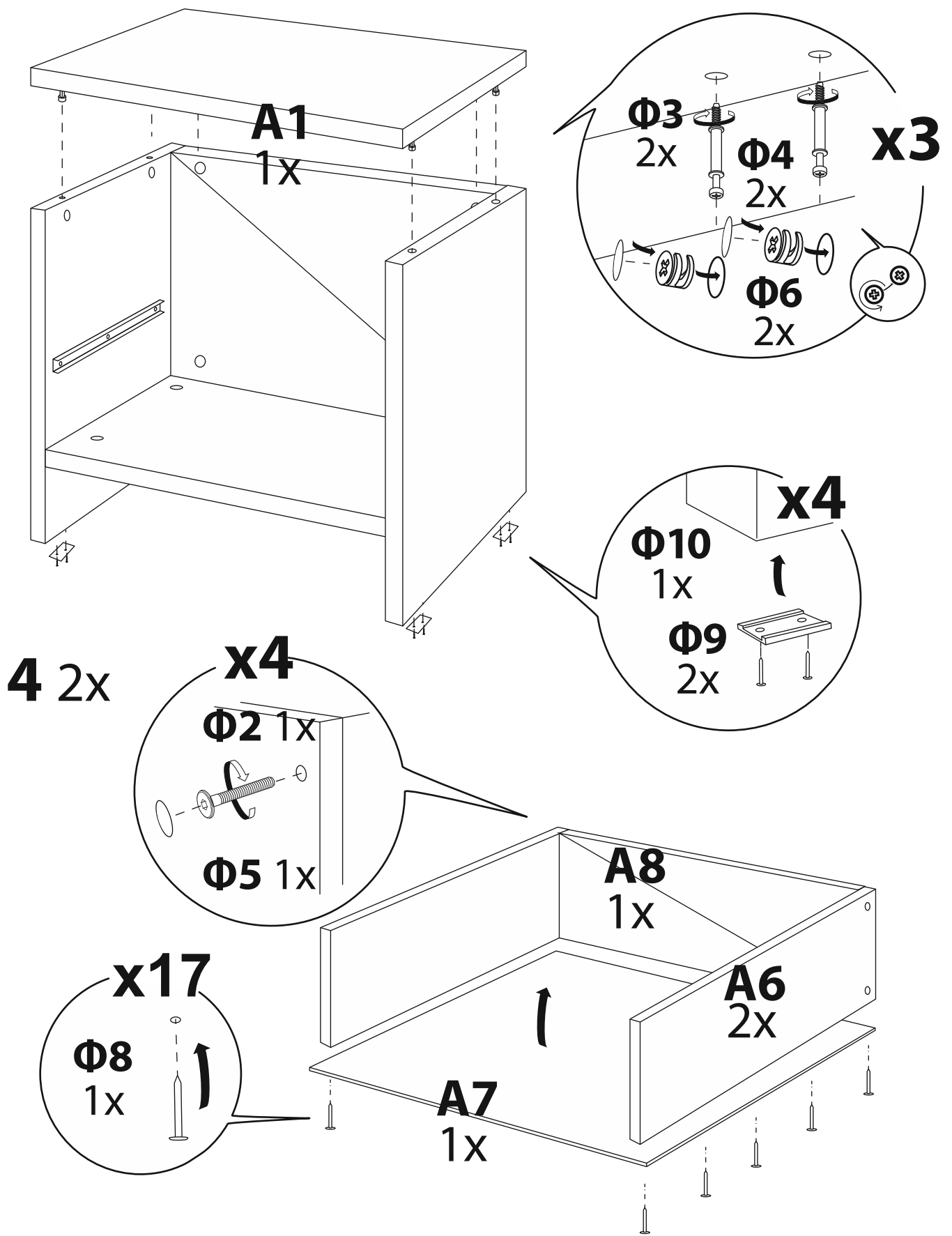

**5**

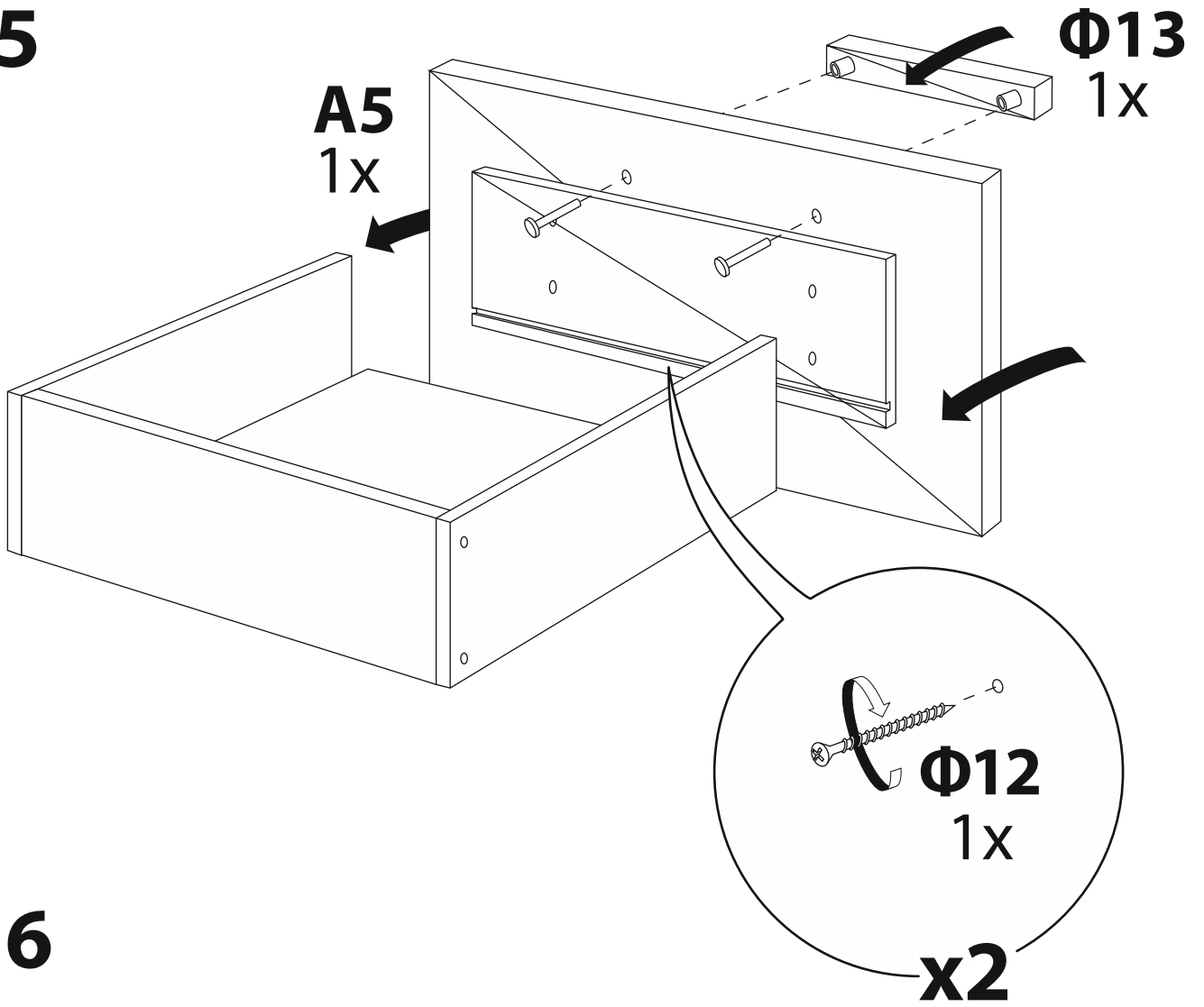

**6**

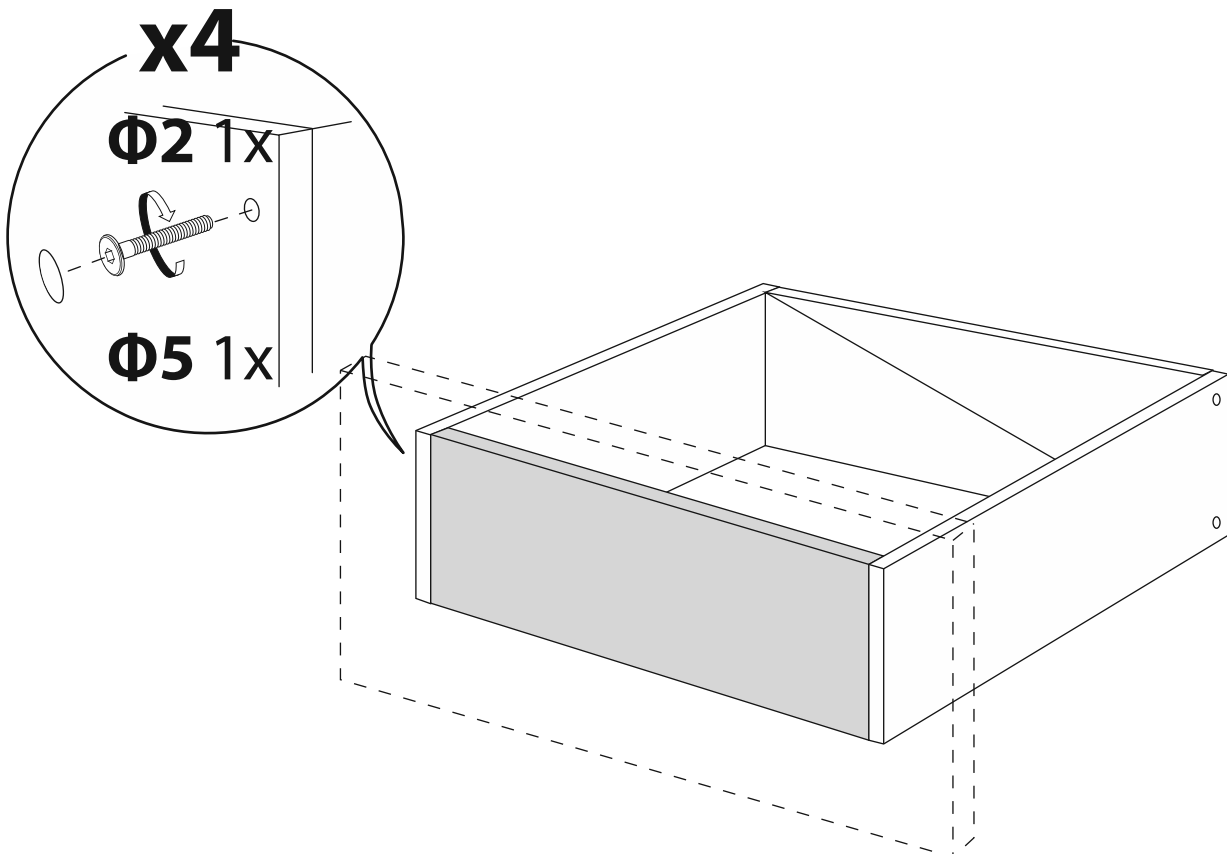

7

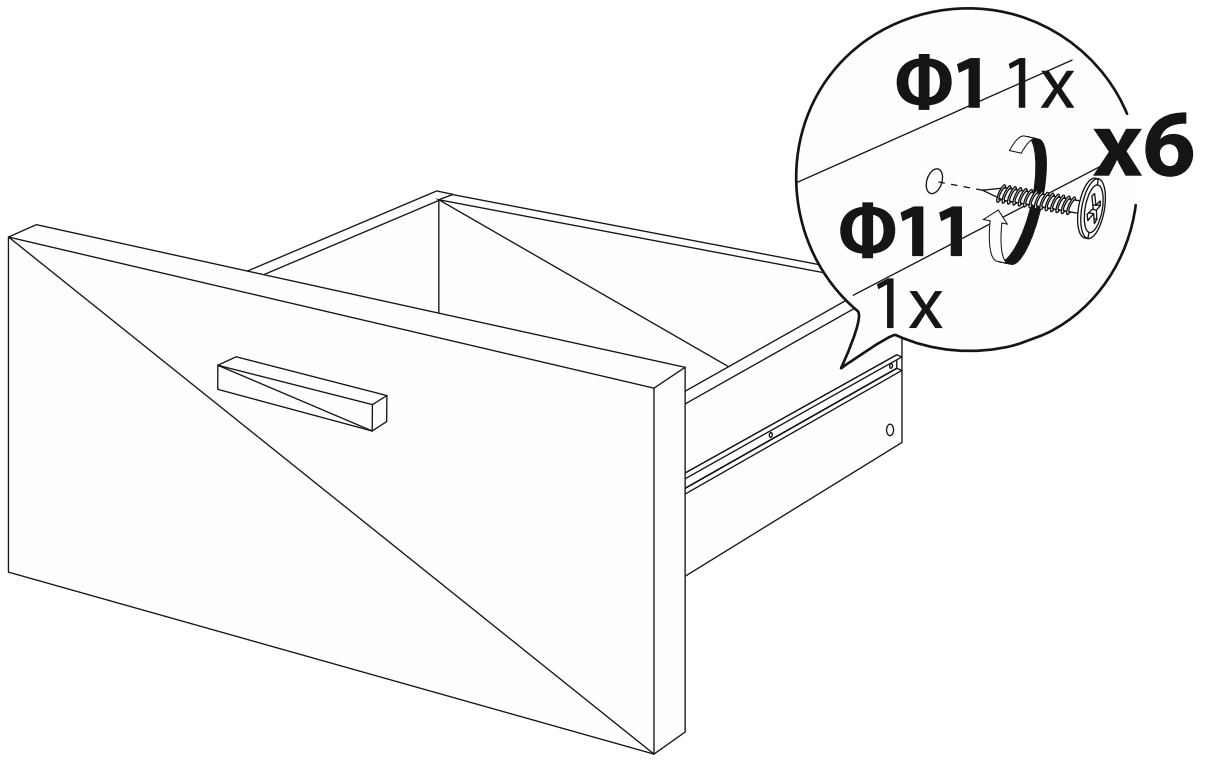

8

